



LiFePO4 Battery System



*Make life full of hope*

# USER GUIDE

LiFePO4 Battery System for Households

☑ English



High voltage energy storage Lithium battery pack



# Contents

<b>1. Introduction</b> .....	1
<b>2. Symbols</b> .....	1
<b>3. Safety</b> .....	2
3.1 Handling .....	2
3.2 Installation .....	2
<b>4. Response to Emergency Situations</b> .....	2
4.1 Fire Situation .....	2
4.2 Warning Labels .....	3
<b>5. Product Information</b> .....	3
5.1 Battery Module Specifications .....	3
5.2 BMS Specifications .....	4
5.3 Battery System Specifications .....	4
<b>6. Product Features</b> .....	6
6.1 Battery System Features .....	6
6.2 Electrical Interface Description of BCU600050 .....	6
6.3 Electrical Interface Description of LPBA48050-OH .....	7
6.4 System Wiring Schematic .....	7
6.5 Switch On / Off .....	7
6.6 Description for Communication port .....	8
<b>7. Installation</b> .....	8
7.1 Items in the package .....	8
7.2 Product size information .....	9
7.3 Tools.....	9
7.4 Floor installation with base .....	10
7.5 Wall-Mounted Installation Process .....	10
7.6 Install Environment.....	12
7.7 Terminal Connection .....	13
7.8 Battery system switch operation .....	13
7.9 Commissioning .....	14
7.10 Terminal Connection .....	14
7.11 Description for Communication port .....	15
7.12 Install protective cover .....	16
<b>8. Commissioning</b> .....	16
8.1 Fault Code Table.....	17
<b>9. Exclusion</b> .....	18
<b>10. DIP switch SW1-SW4 Description</b> .....	18
10.1 Maintenance .....	18
10.2 Troubleshooting.....	18





## 1. INTRODUCTION

The document describes the installation, commissioning, maintenance and troubleshooting of the following high voltage battery listed below.

The battery chemistry of these products is Lithium Iron Phosphate. This manual is designed for qualified personnel only. The tasks described in this document should be performed by authorized and qualified technicians only.

After Installation the Installer must explain the user manual to the end user.

## 2. SYMBOLS

	Caution, risk of electric shock.
	Do not place nor install near flammable or explosive materials.
	Install the product out of reach of children.
	Read the instruction manual before starting installation and operation.
	Do not dispose of the product with household wastes.
	Recyclable.
	Disconnect the equipment before carrying out maintenance or repair.
	Observe precautions for handling electrostatic discharge sensitive devices.
	Protective Class 1.
	Caution, risk of electric shock, energy storage timed discharge.

### SPECIFICATIONS FOR HUC-BMU

The battery system main using Solar power system for Family house. It also have a with to controller the battery easily and protect our Household application timely.

## 3. SAFETY

### 3.1 Handling

- Do not expose battery to open flame.
- Do not place the product under direct sunlight.
- Do not place the product near flammable materials. It may lead to fire or explosion in case of accident.
- Store in a cool and dry place with ample ventilation.
- Store the product on a flat surface.
- Store the product out of reach of children and animals.
- Do not damage the unit by dropping, deforming, impacting, cutting or penetrating with a sharp object. It may cause leakage of electrolyte or fire.
- Do not touch any liquid spilled from the product. There is a risk of electric shock or damage to skin.
- Always handle the battery wearing the insulated gloves.
- Do not step on the product or place any foreign objects on it. This can result in damage.
- Do not charge or discharge damaged battery.

### 3.2 Installation

- After unpacking, please check the product for damages and missing parts.
- Make sure that the inverter and battery is completely turned off before commencing installation.
- Do not interchange the positive and negative terminals of the battery.
- Ensure that there is no short circuit of the terminals or with any external device.
- Do not exceed the battery voltage rating of the inverter.
- Do not connect the battery to any incompatible inverter.
- Do not connect different battery types together.
- Please ensure that all the batteries are grounded properly.
- Do not open the battery to repair or disassemble. Only Felicity is allowed to carry out any such repairs.
- In case of fire, use only dry powder fire extinguisher. Liquid extinguishers should not be used.
- Install the battery away from children or pets.
- Do not use battery in high static environment where the protection device might be damaged.
- Do not install with other batteries or cells.

## 4. RESPONSE TO EMERGENCY SITUATIONS

The batteries comprise of multiple batteries connected in series. It is designed to prevent hazards or failures. However, Felicity cannot guarantee their absolute safety. Under exposure to the internal materials of the battery the following recommendations should be carried out by the user.

- If there has been inhalation, please leave the contaminated area immediately and seek medical attention.
- If there has been contact with eyes, rinse the eyes with running water for 15 minutes and seek medical attention immediately.
- If there has been contact with the skin, wash the contacted area with soap thoroughly and seek medical attention immediately.
- If there has been ingestion, induce vomiting and seek medical attention.

### 4.1 Fire Situation

Use a FM-200 or Carbon Dioxide (CO2) fire extinguishers to extinguish the fire if there is a fire in the area where the battery pack is installed. Wear a gas mask and avoid inhaling toxic gases and harmful substances produced by the fire.

## 4.2 Warning Labels

Warning labels and other relevant labels are attached on the battery pack.

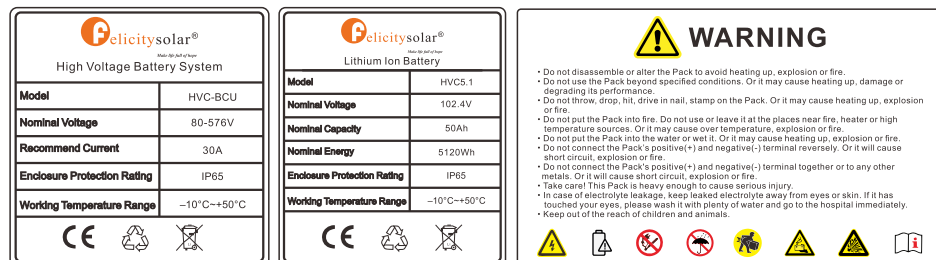

## 5.PRODUCT INFORMATION

1. HVC-BMU is a battery module, it needs to be used with HVC-BCU controller;
2. HVC-BCU is the controller of the whole system, so each system must have one HVC-BCU;
3. Our system consists of at least 1 HVC-BMU + 1 HVC-BCU and up to 5 HVC-BMU + 1 HVC-BCU.

### 5.1 Battery Module Specifications

Specifications For HVC-BMU	
Battery Module	HVC-BMU
Total Energy [Kwh]	5.12
Nominal Voltage [V]	102.4
MAX. Charge Voltage [V]	115.2
MIN. Discharge Voltage [V]	96
Max. Chargeing Current [A]	30
Max. Discharge Current [A]	30
Communication	CAN,RS485
Enclosure Protection Rating	IP65
Working Temperature Range [°C]	-10 ~ 50
Cycle Life	> 6000 Cycle@ 80% DOD / 25°C
Net Weight(KG)	51
Gross Weight(KG)	54
Product Dimension(MM)	600x370x210
Package Dimension(MM)	712x482x328

## 5.2 BMS Specifications

SPECIFICATIONS FOR HVC-BCU	
Model No.	HVC-BCU
Operating Voltage Range(v)	80-576
Max. Charge/discharge Current (A)	30
Total Voltage Measurement Accuracy	±1.0%FSR
Communication	CAN,RS485
Available Soc Range	10%~100%
Charge/discharge Efficiency (%)	>98
Working Temperature Range [°C]	-10 ~ 50
Enclosure Protection Rating	IP65
Net Weight(KG)	12
Gross Weight(KG)	24.5
Product Dimension(MM)	600x370x200
Package Dimension(MM)	712x482x403

### 5.3 Battery System Specifications

SPECIFICATIONS FOR BATTERY SYSTEM					
BATTERY SYSTEM	HVC-5.1	HVC-10.2	HVC-15.4	HVC-20.5	HVC-25.6
Battery Module	HVC-BMU(5.12kwh, 102.4V)				
Number of Modules	1	2	3	4	5
Total Energy [Kwh]	5.12	10.24	15.36	20.48	25.6
Usable Energy [kWh] (90%DOD)	4.6	9.2	13.8	18.4	23
Nominal Voltage [V]	102.4	204.8	307.2	409.6	512
MAX. Charge Voltage [V]	115.2	230.4	345.6	460.8	576
MIN. Discharge Voltage [V]	96	192	288	384	480
Weight [Kg]	51	102	153	204	255
Dimension [W x D x H, mm]	600/370/(322+210xN)				
Max. Chargeing Current [A]	30				
Max. Discharge Current [A]	30				
Communication	CAN, RS485				
Enclosure Protection Rating	IP65				
Working Temperature Range [°C]	-10 ~ 50				

Cycle Life	> 6,000 Cycle@ 80% DOD / 25°C / 0.5C, 60%EOL
Warranty	10 years
Certification	IEC62619, UN38.3, CE
Cycle Life	> 6,000 Cycle@ 80% DOD / 25°C / 0.5C, 60%EOL
Battery Designation	IFpP24/141/161/[(1P32S)nSJ]E/-20+60/90

**Charging method:**

When the battery and inverter establish communication, the constant current of 30A is charged until the battery voltage reaches 112V \* N, and then the current decreases linearly until the voltage reaches 115.2V \* N and the current drops to 0A (N is the number of battery packs in series)

## 6. ELECTRICAL CONNECTIONS

### 6.1 Battery System Features

The batteries have been fitted with multiple protection systems to ensure the safe operation of the system. Some of the protection system includes:

- Inverter interface protection: Over voltage, Over current, External Short Circuit, Reverse Polarity, Ground Fault, Over Temp, In rush current.
- Battery Protection: Internal Short Circuit, Over voltage, over current, over temp, Under voltage The battery system contains the following Interface to allow it to connect and operate efficiently.

### 6.2 Electrical Interface Description of Control cabinet

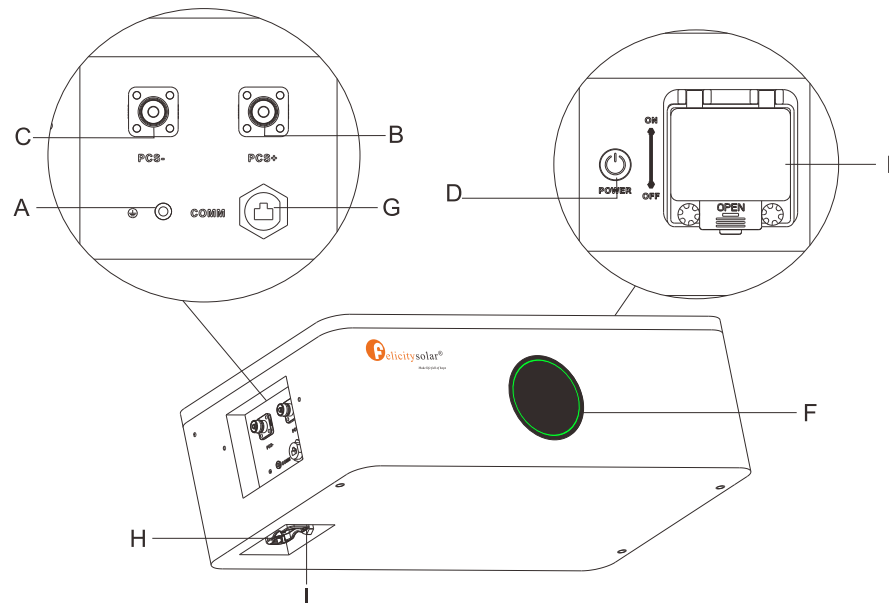

Code	Name
A	Earth Terminal
B	PCS +
C	PCS -
D	Power Switch
E	Breaker
F	LCD display
G	PCS Communication
H	Blind plug terminal
I	Bleed valve

### 6.3 Battery box introduction

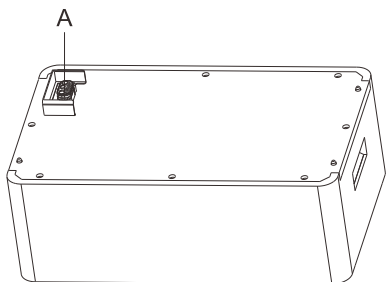

Code	Name
A	Blind plug terminal

### 6.4 Base introduction

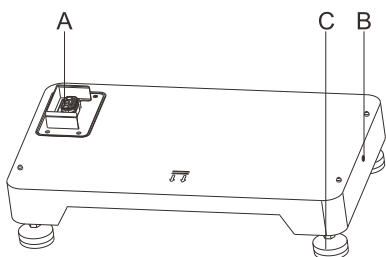

Code	Name
A	Blind plug terminal
B	Earth terminal
C	Foot cup

### 6.5 Battery system introduction

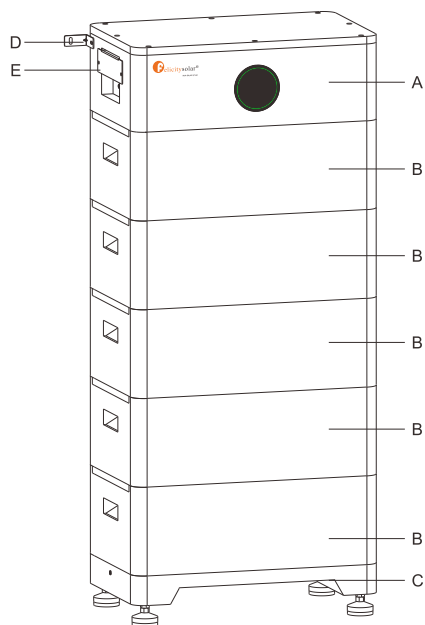

Code	Name
A	Control cabinet
B	Battery box
C	Pedestal
D	Fixed trestle
E	Safety shield

### 6.6 Switch On /Off

Switch on: close the breaker to the ON block, press and hold Power switch for 2-3 seconds, the battery will perform self-test before output. The LCD will show SOC.

Switch off: close the breaker to the OFF block, the battery will shut down directly.

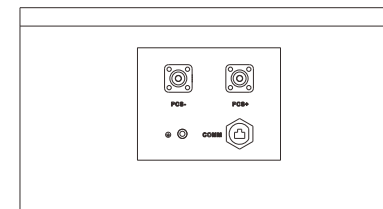
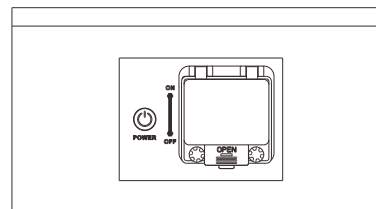



## 7. INSTALLATION

### 7.1 Items in the package

Packaging information

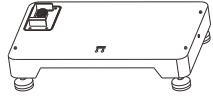
- The battery system consists of a battery, a control box, and a base.
- Before unpacking the battery system, check whether the packaging is damaged and check the battery system model. If anything goes wrong, Do not open the packing case, and contact the after-sales service center as soon as possible.
- After unpacking the battery system, check the completeness of the product delivery against the packaging information. If there is any anomaly, please contact the after-sales service center as soon as possible.

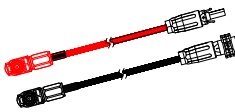
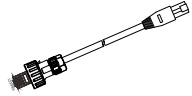
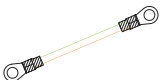
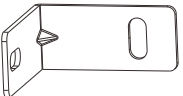
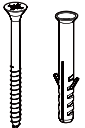
FOR HVC-BCU600050		
 Control cabinet x1	 Pedestal x1	 Instructions x1
 Power line x1	 Communication line x1	 Ground wire x1
 Fixed trestle x2	 Distribution screw x2	

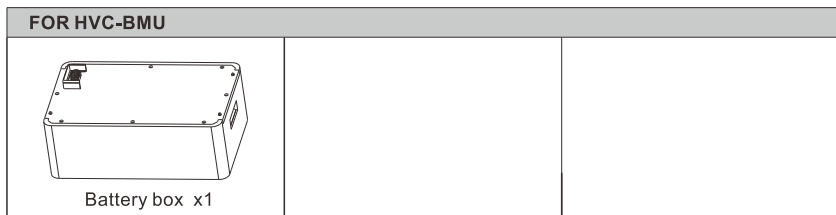

### 7.2 Product size information

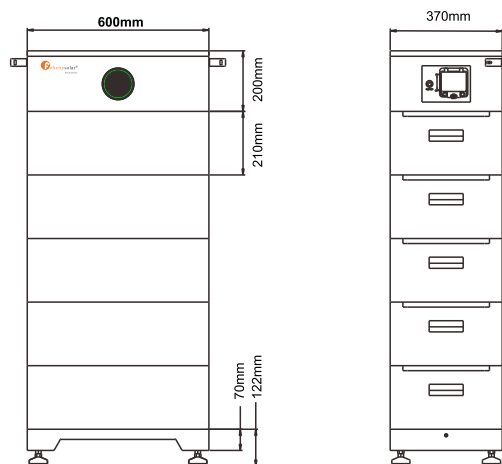

### 7.3 Tools

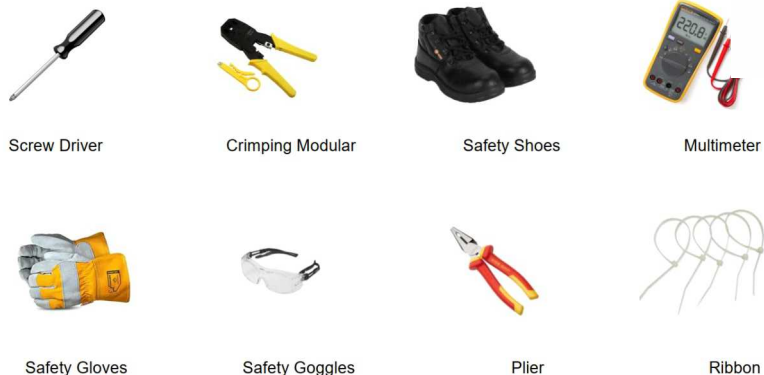

### 7.4 Floor installation with base

#### Installation Location Requirements

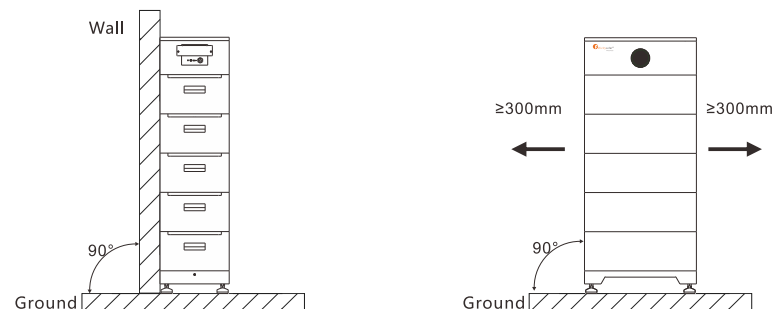

#### Step 1:

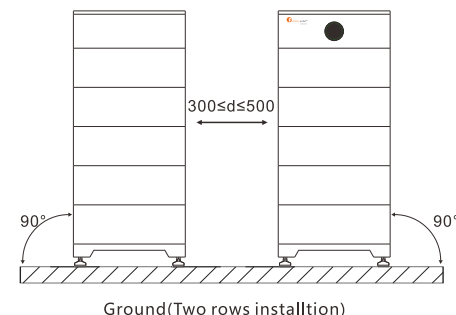

### 7.5 Installation Procedure

- Step 1: Remove the battery, base and control box from the carton.
- Step 2: Place the base against the wall.
- Step 3: Install 1~5 battery boxes on the base, and then place the control box above the installed battery to ensure it is firmly placed.
- Step 4: Install the anti-tipping bracket of the control box, mark the punching position with a marker, and remove the anti-tipping bracket and the control box.
- Step 5: Use the impact drill to drill holes. (Aperture: 10mm, depth: 60mm).
- Step 6: Use a hammer to knock the plastic plug into the hole, fit it to the wall, then reinstall the control box and the anti-tipping bracket, and tighten the screws on the anti-tipping bracket. The torque requirement is 10N · m to ensure that the control box is firmly installed.

Step 1:

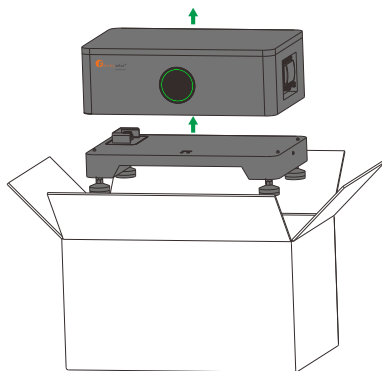
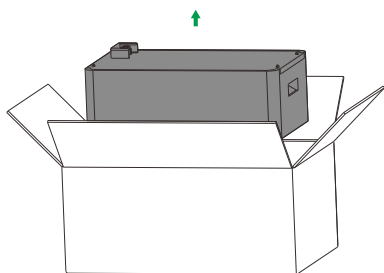

Step 2:

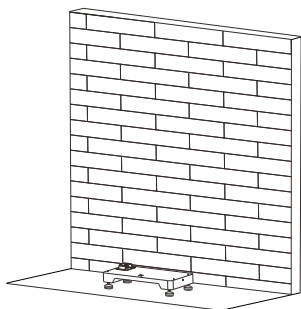

Step 3:

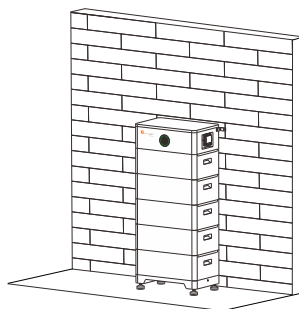

Step 4:

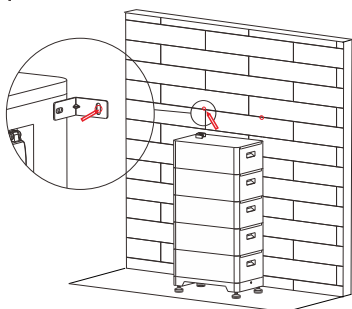

Step 5:

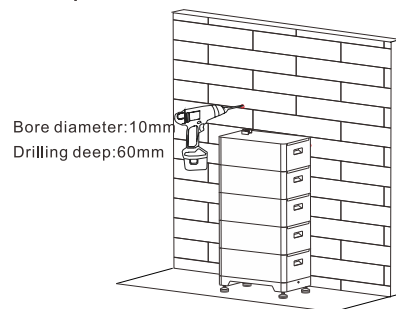

Step 6:

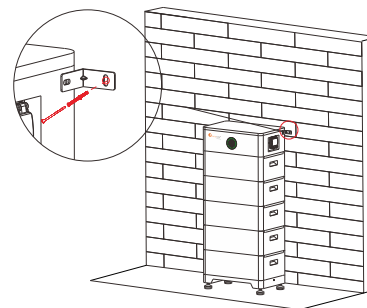

Step 7:

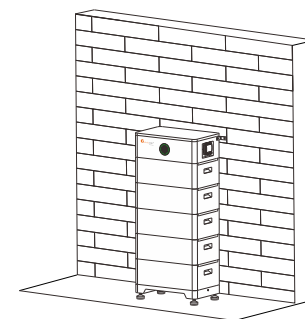

**Note:**

1. Check that the ground is flat and free of tilt before installation.
2. Make sure that the base is vertical and close to the ground.
3. Make sure that the base is against the wall and the arrow direction on the base faces outward when placing.
4. When placing the upper battery, make sure that the upper and lower hole positions are aligned.
5. Be careful of the battery falling.
6. Avoid installing the anti-tipping bracket on the same side

**7.6 Install Environment**

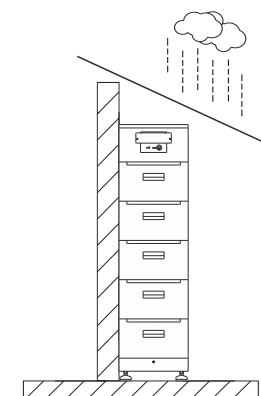
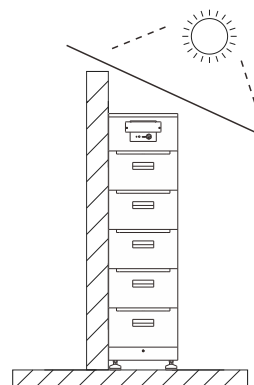



### 7.7 System Wiring Schematic

Matching side inverter IVGM100600

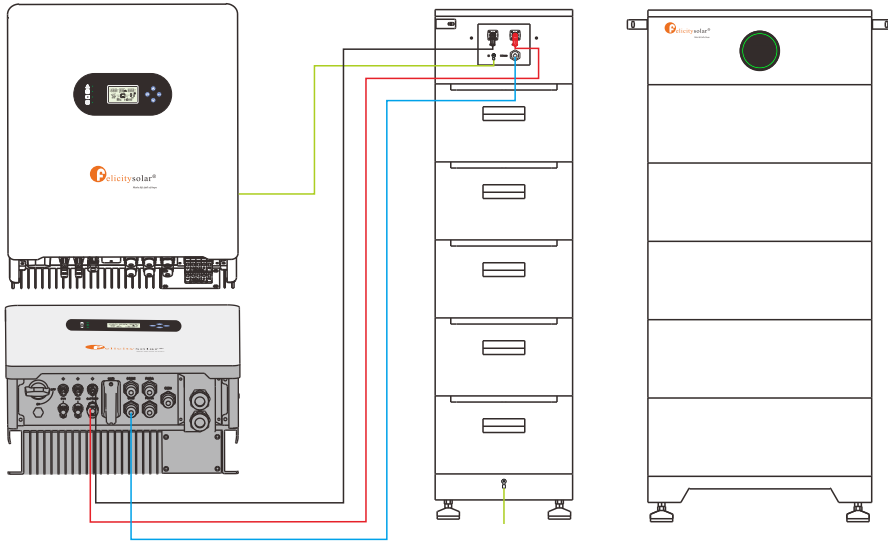

### 7.8 Ground connection

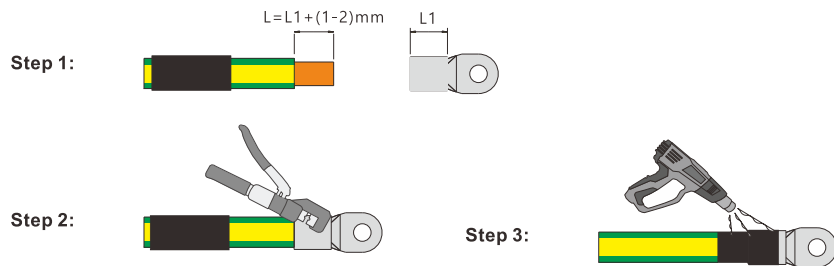

- Note:
- When installing equipment, the protective ground wire must be installed first;
  - When removing the equipment, the protective ground wire must be removed finally.
  - The drawing force after crimping shall be greater than 400N.
  - The control box is connected to the ground wire of the base.

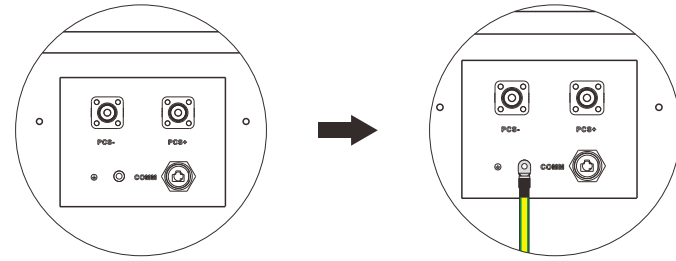

Note: Press the position indicated in the figure above before disconnecting the power terminal.

### 7.9 Powerline connection

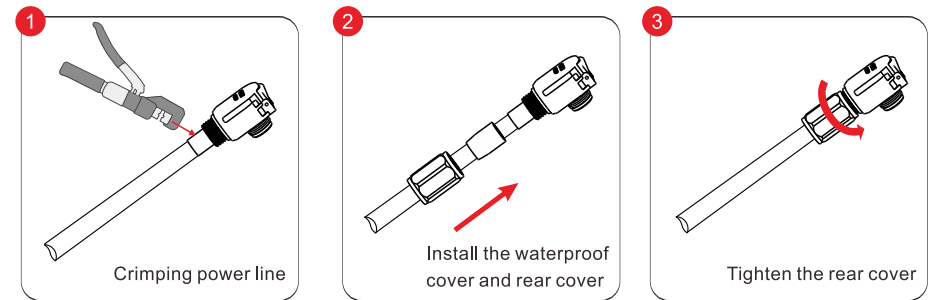

### 7.10 Terminal Connection

Power terminal

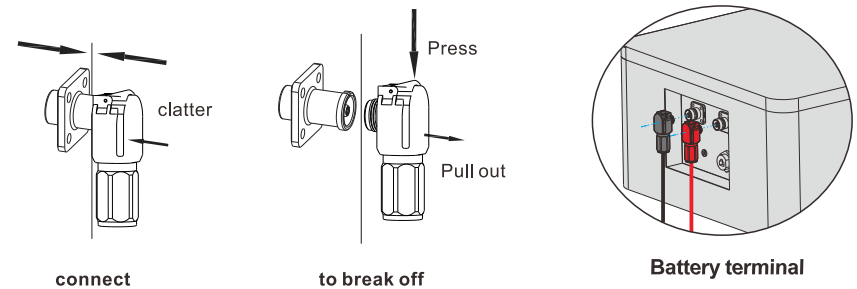

Note: Press the position indicated in the figure above before disconnecting the power terminal.

#### Step 1. Prepare PV positive and negative power cables

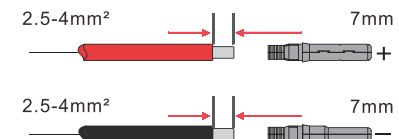

**Step 2.** Connect PV cables to PV connectors. See Figure 4.1-2.

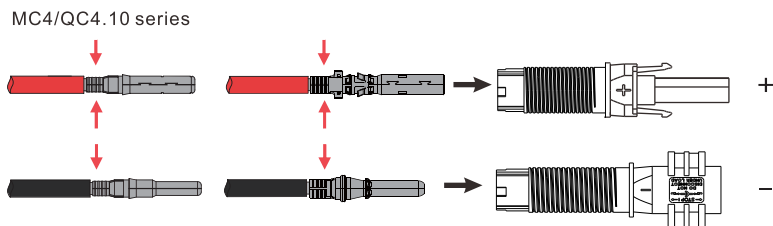

**Step 3.** Screw the cap on and plug it onto inverter side. There will be a click sound if connectors are inserted correctly into PV plugs. See Figure 4.1-3.

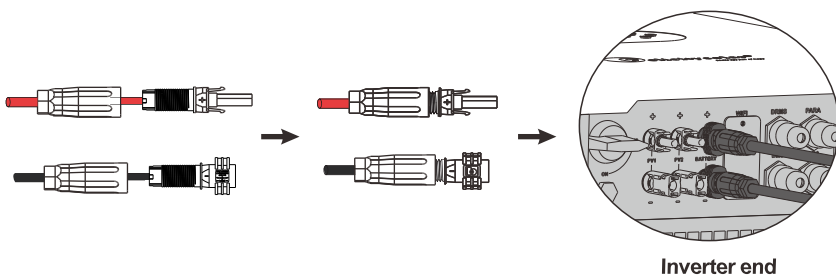

**7.11 Description for Communication port**

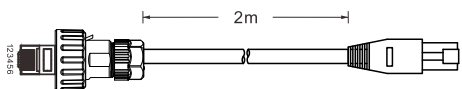

RS-485

Pin	Function Definitions	Function Declaration
1	GND	Power/signal ground
2	12V	
3	NC	
4	NC	
5	485B	RS485-B
6	485A	RS485-A
7	NC	CANL_PCS
8	NC	CANH_PCS

**7.12 Install protective cover**

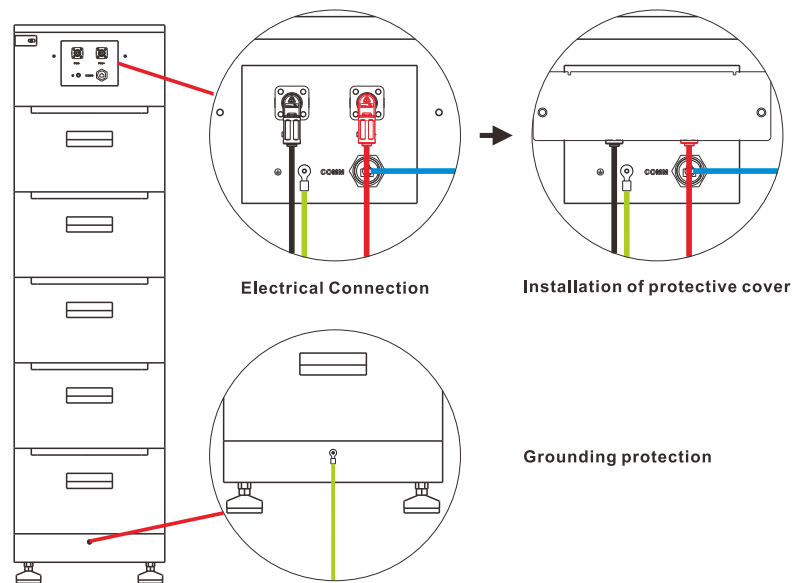

**8. LCD Display Icons**

100%

Battery Information	
	Indicate SOC.
Fault information	
	Indicates a fault.
State	
	When the battery is charged, the lcd light will turn on clockwise, and then the current SOC will be displayed, and the cycle will continue; When the battery is discharged, the current SOC is displayed If there is still a fault, the fault code is displayed

## 8.1 Fault Code Table

FAULT CODE	EXPLAIN	TREATMENT MEASURE
01	Battery Voltage High	Stop charging
02	Battery Voltage Low	Stop discharging
03	Cell Voltage High	Stop charging
04	Cell Voltage Low	Stop discharging
05	Charging Current High	Reduce charging current
06	Discharging Current High	Reduce discharging current
07	Bms Temperature High	Stop charging and discharging ,wait for the temperature to drop
08	Bms Temperature Low	Wait for temperature rise
09	Cell Temperature High	Stop charging and discharging , wait for the temperature to drop
10	Cell Temperature Low	Wait for temperature rise
11	Afe fault	Restart, if the fault still exists, contact our engineer
12	Soft Start Failed	Restart, if the fault still exists, contact our engineer
13	Slave Communication Failure	Check for poor contact of the communication line
14	Output Impedance Low	Restart, if the fault still exists, contact our engineer
15	Slave Mcu Communication Failure	Restart, if the fault still exists, contact our engineer
16	Slave Version Fault	Contact our engineer to upgrade the progra

## 9. WARRANTY

The warranty shall not cover the defects caused by normal wear and tear, inadequate maintenance, handling, storage faulty repair, modifications to the battery or pack by a third party other than Felicity, failure to observe the product specification provided herein or improper use or installation, including but not limited to the following.

- Damage during transport or storage.
- Incorrect Installation of battery into pack or maintenance.
- Use of battery pr pack in inappropriate environment.
- Improper, inadequate, or incorrect charge, discharge or production circuit other than stipulated herein.
- Incorrect use or inappropriate use.
- Insufficient ventilation.
- Ignoring applicable safety warnings and instructions.
- Altering or attempted repairs y unauthorized personnel.
- In case of force majeure (ex: lightning, storm, flood, fire, earthquake, etc.).
- There are no warranties-implied or express-other than those stipulated herein. Felicity shall not be liable for any consequential or indirect damages arising or in connection with the product specification, battery or pack.

## 10. TROUBLESHOOTING AND MAINTENANCE

### 10.1 Maintenance

- 1.Regularly check whether the service environment of the battery meets the requirements, and the installation position should be far away from the heat source.
- 2.In case of one of the following situations, it needs to be charged in time:
  - The battery is often under charged;
  - The battery has been out of use or stored for more than 3 months.
- 3.Regularly check whether the battery and its supporting terminals, connecting cables and indicator lights are normal.

### 10.2 Troubleshooting

When the red / white LCD on the panel is flashing or normally on, it does not mean that the Battery system is abnormal, it may be just an alarm or protection. Please check the 'LCD fault message' in chapter 7 for the detailed faulty definition before any trouble-shooting steps. In general, the alarm indication is normal without manual intervention. When the alarm triggering state is removed, Battery system will automatically return to normal use.

#### - Problem determination based on the following points

- Whether the red light on the BCU600050 is on;
- Whether the battery can be output voltage or not.
- Whether the battery system can be communicated with inverter;

#### - Preliminary determination steps

LiFePO4 Battery System for HouseholdsBattery system cannot work, when DC switch on and POWER on, the LCD doesn't light up or flash, please consider contact the local distributor.

- The LCD display of BCU600050 is normal, but it cannot charge and discharge. Observe the display screen of inverter and there is no SOC. Please check whether the CAN communication between BCU600050 to inverter is well connected. If the connection is good, please replace a CAN communication cable. If the SOC is still not visible on the inverter display screen, please contact the local distributor.
- After the battery system is powered on, if you can see the alarm information on the LCD and inverter display screen at the same time, please contact the local distributor.